

By Michael Reading, Douglas J. Hourston, Mo Song, Hubert M. Pollock, and Azzedine Hammiche

# Thermal analysis for the 21st century

**T**HERE ARE THREE major problems that arise when using current thermal methods. The first is a purely practical one: Experiments often take too long, especially thermomechanical measurements. The second is related to sampling: Frequently, the sample is either too small, too thin, or buried within a larger component from which it is difficult to extract. The third is more fundamental: The information they provide is not spatially resolved.

The first two points will be easily understood by many thermal methods practitioners, especially from industry. The solution to urgent problems is often delayed by the slowness of, in particular, thermomechanical analysis (TMA) and dynamic mechanical analysis (DMA) measurements. Similarly, the problems of gathering sufficient sample when trying to make a measurement on a thin film that is firmly adhered to a substrate or sandwiched between two other layers will be familiar to many. The third point perhaps requires more explanation.

Thermal methods are particularly useful in the study of polymer and polymer-containing samples. Modern polymeric materials are usually blends or composites with complex morphologies that are crucial to determining their material properties. Thermal methods are very useful for obtaining morphological information for these systems. The development a few years ago of modulated temperature differential scanning calorimetry (MTDSC) by Reading and co-workers<sup>1</sup> has greatly increased the quality of the structural information that can be obtained by calorimetry. In this technique, a sine wave (or square wave) modulation is superimposed on the conventional temperature program and a Fourier

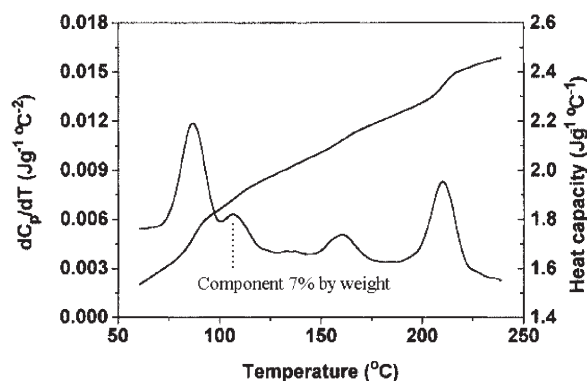
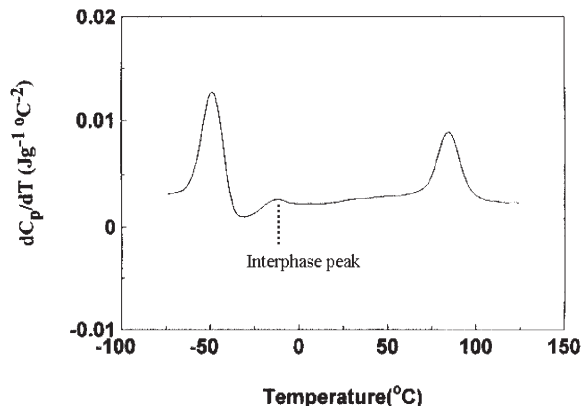

**Figure 1** Mixture of four polymers. (Figure reproduced with permission from Ref. 6.)

transform analysis is applied to the resultant data. A full review of MTDSC is beyond the scope of this article; however, the advantages include the following: reversing and nonreversing processes can be separated, and there is considerable improvement in the sensitivity and resolution with which glass transitions can be measured. MTDSC offers unique benefits for studying curing systems<sup>2,3</sup> and semicrystalline polymers,<sup>4</sup> but this article will focus on its application to polymer blends and related systems.

The authors have demonstrated how the differential with respect to temperature of the reversing heat capacity determined by MTDSC can be used as a highly sensitive quantitative probe for determining the number of phases and presence of interphases in polymer blends.<sup>5,6</sup> For example, *Figure 1* shows how four phases can be easily detected in one sample even when one of the phases is present only at a level of 7% by weight. *Figure 2* shows a PnBA (poly[n-butyl acrylate])+ PVC (polyvinylchloride) system in which the presence of an interphase can be seen. *Figure 3* is the result of a blend of styrene isoprene styrene triblock copolymer with polystyrene. The absence of a well-defined peak for polystyrene implies that there must be a polyisoprene-polystyrene interphase with a continuous gradation of composition. These examples illustrate how powerful MTDSC can be for giving insight into polymer morphology. However, these results say nothing about the

Dr. Reading, Prof. Hourston, and Dr. Song are with IPTME, Loughborough University, Loughborough LE11 3TU, U.K.; tel.: 011 44 1509 263171; fax: 011 44 1908 223949; e-mail: -mike\_reading@msn.com. Dr. Pollock and Dr. Hammiche are with the School of Physics and Chemistry, Lancaster University, Lancaster, U.K.



**Figure 2** Blend of PnBA and PVC showing the presence of an interphase that has developed after annealing at 135 °C for 1 hr. (Figures reproduced with permission from Ref. 6.)

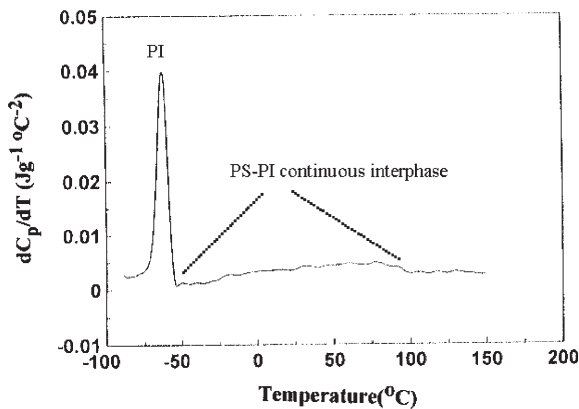

**Figure 3** Blend of styrene-isoprene-styrene triblock copolymer and polystyrene (28% by wt.). PI = polyisoprene and PS = polystyrene. (Figure reproduced with permission from Ref. 6.)

size of the domains and how they are distributed in space. For this information, the experimenter must turn to microscopy. However, the forms of microscopy currently available can show structure but do not reveal the chemical composition of the features observed. For this reason, the interpretation of microscopic images is often uncertain, especially in complex real-life systems that typically consist of many components.

On one hand, there is a thermal technique that provides valuable information on the number and type of phases and interphases, but no spatial information; and on the other hand, a microscopic technique that shows structure but does not show which feature corresponds to which phase. To solve this problem, a form of thermal microscopy has been created that enables thermal analysis to be carried out on a micro scale.<sup>7-11</sup> In doing this, the authors have not only made it possible to obtain spatially resolved thermal information, but have also provided a rapid form of thermal analysis that can

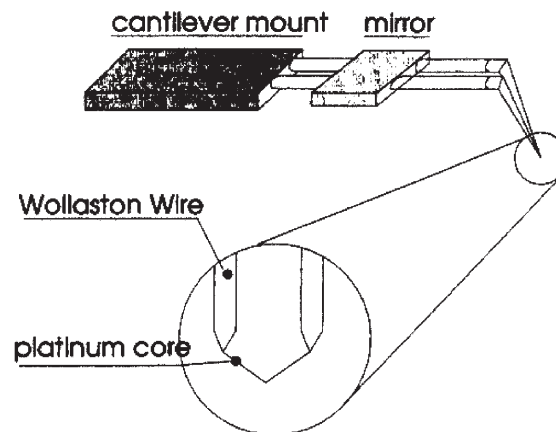

**Figure 4** Schematic diagram of the AFM-cantilever used in the CASM-instrument.

overcome many of the sampling problems outlined in the first paragraph.

#### *Calorimetric analysis with scanning microscopy (CASM)*

Atomic force microscopy (AFM) is a technique in which the tip of a probe is rastered over a surface to build up an image of the surface topography. It can achieve very high, even atomic, resolution. The apparatus is based on a conventional AFM, but the tip of the probe has been replaced by an ultraminiature resistive heater. The resistance also serves as a means of measuring temperature; thus, the tip, when used in conjunction with a reference probe, serves as a micro MTDSC cell. A schematic diagram of the cantilever used is shown in Figure 4. When imaging, the probe tip is held at some constant average temperature, a little above that of the sample, while a temperature modulation of a few degrees is applied at frequencies in the kHz range. The tip is rastered over the sample surface in contact mode to build up an image. The data collected are the topography, as in traditional AFM, plus thermal conductivity, measured from the average (dc) signal plus thermal diffusivity, as measured from the response to the modulation (ac) signal. Figure 5 shows a typical image of a polymer blend. It can be seen that the phases give very different thermal contrast whereas optical and electron microscopy would see them as being very similar. If the thermal properties of the individual components are known, this image is sufficient to identify the continuous and the discontinuous phase. If they are not known, the apparatus can easily be used to measure them.

In this example, the dc and ac images are very similar, but one important aspect of the ac signal is that the depth it probes can be controlled by controlling the frequency of the modulation. This is illustrated in Figure

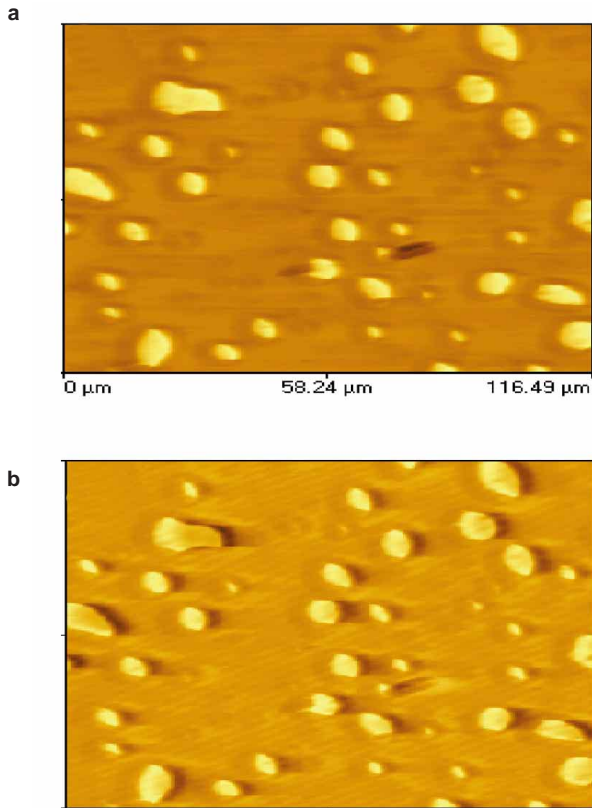

**Figure 5** Thermal image of domains of PMMA (polymethylmethacrylate) within a CPE-(chlorinated polyethylene) matrix: a) dc-image, b) ac-image, taken at 10 kHz.

6. Here, the sample consists of a circle of high-thermal-diffusivity material located within a matrix of lower-thermal-diffusivity material, both of which are covered by a polymer film. When the modulation frequency is low, the ac image sees through the polymer layer and detects the buried island of high thermal diffusivity. When the frequency of the modulation is increased, the thermal signal becomes uniform, since the probe can no longer see through the polymer layer. This type of depth profiling is similar in some ways to confocal microscopy, but has the distinct advantage that even optically opaque materials can be looked through.

Having imaged the sample, any point in the image can be selected, and the probe tip placed on it. The temperature of the tip can then be scanned in exactly the same way as conventional thermal analysis. The use of modulation is advantageous for this type of experiment since it limits the volume of the sample being analyzed because the ac signal is only sensitive to changes close to the resistive heater (the volume being controlled by the frequency of the modulation). In the current configuration, the most sensitive signal to transitions is the derivative of the phase angle. *Figure 7* shows the results for three repeat runs from different points on the surface

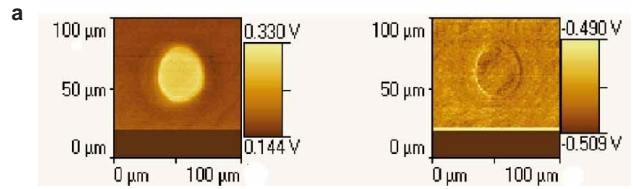

**Figure 6** Two ac-thermal images of a sample with an island of high-thermal-conductivity material within a matrix of low-thermal-conductivity material, over both of which there is a polymer coating. Image (a) was taken at 1 kHz and (b) at 30kHz.

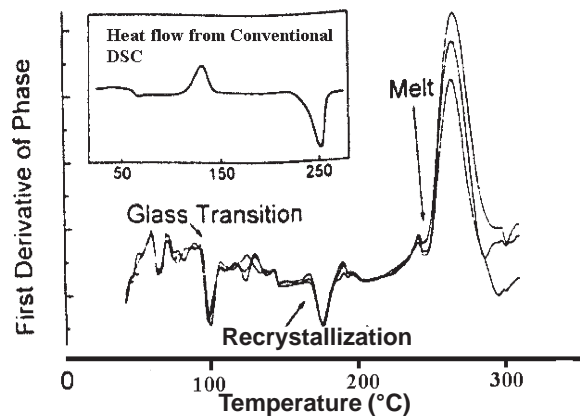

**Figure 7** Repeat CASM-temperature scans for quenched PET with the conventional DSC-result shown in the inset.

of a sample of quenched polyethylene terephthalate (PET). It should be noted that this sample is homogeneous; thus, all points should be the same. The glass transition, crystallization, and melting events are all observed. It can be seen that the results are very reproducible. There are some differences in the temperatures of the transitions when compared to bulk measurements. This may, in part, come from surface effects and also, in part, be due to the fact that heating (and cooling) rates used in CASM experiments are on the order of 600 °C/min. The modulation is sensing a volume of a few cubic microns. The tip is on the order of tens of cubic microns in size. Such small masses can be heated and cooled very rapidly without the problems of large temperature gradients that would occur with the larger samples associated with conventional thermal methods. This is the CASM technique.

### Mechanothermal analysis with scanning microscopy (MASM)

When the tip is placed on a selected point, a carefully controlled force is applied to it. As the temperature increases, the sample often softens and the probe

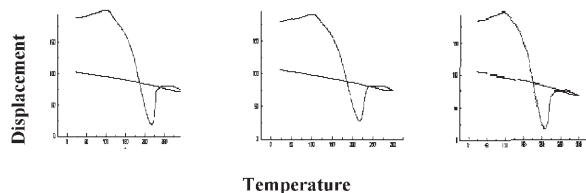

Figure 8 Repeat MASM temperature scans for polystyrene.

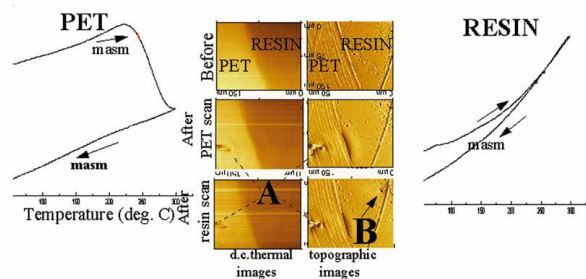

Figure 9 MASM results for a composite consisting of PET in a cross-linked resin matrix showing both heating and cooling data (images are  $50 \times 50 \mu\text{m}$ ).

indents further into the sample. This measurement is closely analogous to a TMA measurement. In Figure 8, a series of measurements on polystyrene show how a softening point can be determined. This determination can be carried out simultaneously with a CASM measurement. This technique is called MASM.

A composite is shown in Figure 9 that consists of a strip of PET-embedded in a cross-linked matrix. MASM results show how the melting temperature of the PET is clearly seen from the MASM scan on the PET, while the cross-linked matrix shows a diffuse glass transition. Imaging after the MASM experiments shows the points at which the measurements were made. As can be seen, the effect of the temperature scan is highly local.

In Figure 10, a composite material is shown that includes a copper electrode and a series of bonded layers of different polymers. The melting behavior of the electrically conducting ink layer can be analyzed at different points, as illustrated by the MASM data shown. The results clearly show the lack of homogeneity. Work in progress is investigating the relationship between this and the electrical properties of the ink that can also be mapped using the CASM probe as one electrode and the copper strip as the other.

The technique described above is known as Static-MASM because no force modulation is used. When force modulation is applied, we have the microequivalent of DMA. This is called Dynamic MASM. Figure 11 gives the recent results demonstrating this new mode.

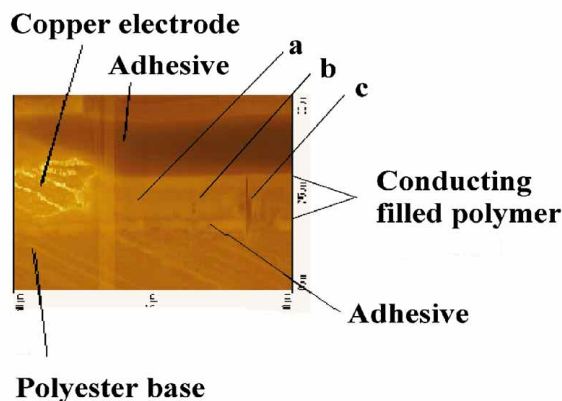
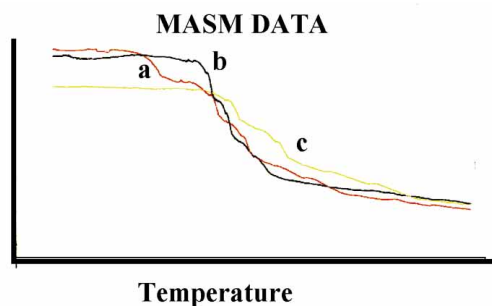

Figure 10 MASM results for a composite consisting of several layers including a copper electrode and a conducting filled polymer film within which the MASM-scans were made.

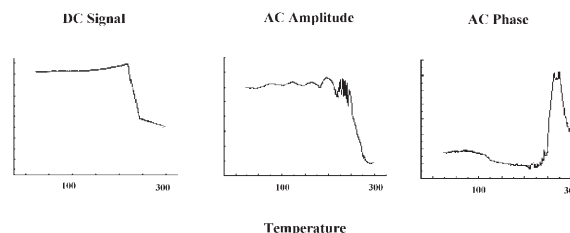

Figure 11 Dynamic MASM temperature scan (equivalent to micro-DMA) on a nylon sample.

### Conclusions

A new family of thermal methods has been created. Images can be generated on the basis of thermal conductivity and thermal diffusivity. Nondestructive depth profiling can be carried out by varying the frequency for the temperature modulation. Any point on an image can be selected and local calorimetric and thermo-mechanical measurements can be made in order to identify the selected component. This apparatus enables extremely fast experiments to be carried out, providing advantages even if all that is required is the measurement of the glass transition of a homogeneous material. Very small amounts (cubic microns) of material can be analyzed including very thin films and sam-

ples buried within composites. Currently, the resolution is approx. 0.5  $\mu\text{m}$  and the calorimetric information is nonquantitative, but progress on both of these points is expected in the near future. For example, temperature measurements have been made on a scale of a few tens of nanometers;<sup>12,13</sup> thus, there is no real obstacle to CASM measurements being possible on this scale. Also, correlations between CASM data and MTDSC measurements of crystallinity have been demonstrated.

#### *Future prospects*

There are future possibilities for additional modes of operation. Photothermal measurements using IR radiation have already been shown to be possible using the CASM probe. This opens the way for IR microscopy at well below the diffraction limit of IR radiation, ultimately on a scale of 20–30 nm. In addition, the authors have demonstrated the ability of the probe to create pyrolysis craters by pulse heating a point on the surface. This then opens up the prospect of analyzing the evolved gases using MS and even GC MS. These two methods of obtaining chemical information can be combined with the physical and structural information provided by CASM and MASM to create a powerful form of analytical microscopy with application in materials science, pharmaceuticals, catalysts, films, electronic components, forensic science, foods, and biological systems.

#### **References**

1. Reading M. Modulated differential scanning calorimetry—a new way forward in materials characterisation. *Trends Poly Sci* 1993; 1:248–53.
2. Van Hemelrijck A, Van Mele B. MTDSC, characterisation of curing systems by TTT and CHT diagrams. *J Therm Anal* 1997; 49:437–42.
3. Van Assche G, Van Hemelrijck A, Van Mele B. MTDSC, considerations for a quantitative study of thermosetting systems. *J-Therm Anal* 1997; 49:443–7.
4. Ishikiryama K, Wunderlich B. Crystallisation and melting of poly(oxyethylene) analysed by temperature-modulated calorimetry. *J Poly Sci*, submitted.
5. Song M, Hammiche A, Pollock HM, Hourston DJ, Reading M. Modulated differential scanning calorimetry:-IV. Miscibility and glass transition behavior in poly(methyl methacrylate) and poly(epichlorohydrin) blends. *Polymer* 1996; 37(25):5661–5.
6. Hourston DJ, Song M, Hammiche A, Pollock HM, Reading M. Modulated differential scanning calorimetry:-VI. Thermal characterisation of multicomponent polymers and interfaces. *Polymer* 1997; 38(1):1–7.
7. Lawson NS, Ion RH, Pollock HM, Hourston DJ, Reading M. Characterising polymer surfaces—nanoindentation, surface force data, calorimetric microscopy. *Phys Scripta* 1994; T55:199.
8. Hammiche A, Pollock HM, Song M, Hourston DJ. Sub-surface imaging by scanning thermal microscopy. *Meas Sci Tech* 1996; 7:142–50.
9. Hammiche A, Reading M, Pollock HM, Song M, Hourston DJ. Localised thermal analysis using a miniaturised resistive probe. *Rev Sci Instr* 1996; 67:4268–74.
10. Pollock HM, Hammiche A, Song M, Hourston DJ, Reading M. Interfaces in polymeric systems as studied by C.A.S.M.—a new combination of calorimetric analysis with scanning microscopy. *J Adhes* 1997, accepted.
11. Hammiche A, Song M, Pollock HM, Hourston DJ, Reading M. Phase separation of miscible blends: a study by SThM and MT-DSC. *Polymeric Materials Preprints* (American Chemical Society's Division of Polymeric Materials: Science and Engineering) 1996, preprint no. 186.
12. Hopson TJ, Legge RN. Simultaneous high resolution topographical and thermal imaging using a diamond tipped thermocouple. NIBT/912, Gaithersburg, MD.
13. Lue K, Shi-Z, Lai J, Majunder A. Nanofabrication of sensors on cantilever probe tips for scanning multiprobe microscopy. *Appl Phys Lett* 1996; 63(3):15.